

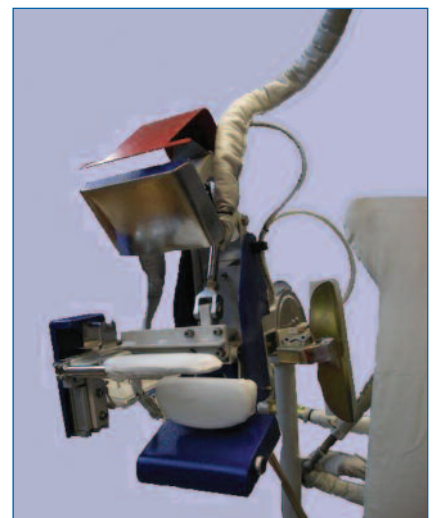

FULLY AUTOMATIC BODY SHIRT FINISHER MOD BP 1808 SINGLE

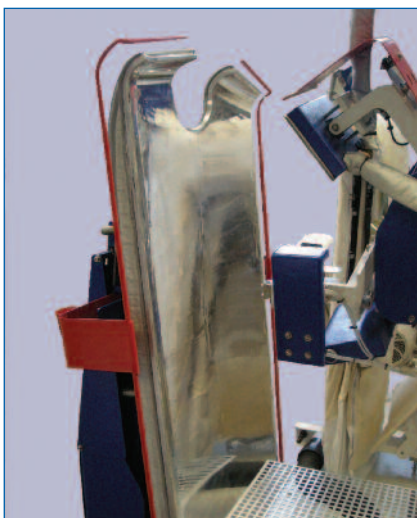

Made in Italy with Italian Fashion Mind



Main features :

- Polished front and back heads – steam heated.
- New injection system to spray steam and air into the entire body and sleeve.
- Drying air to finish the back yoke and sides.
- Improved side air-bag to avoid wrinkles.
- Shoulder and yoke pressing device. Vent pressing device.
- Gentle tensioning sleeve clamps for long and short sleeves.
- User friendly touch screen panel with adjustment of sleeve steaming time, steam mixed with hot air time, vacuum time, body pressure time and blowing time and quantity.
Available to set up 9 different working programs .
- Electronic inverter for blowing quantity adjustment.
- Flat heads to achieve best heating and pressure.
- All the functions are foot pedal control, collar clamp, pleat finishers, body vacuum & start of cycle.
- Two independent super powerful motors, for vacuum and blowing.
- Automatic collar clamp opening at the end of the cycle.
- Blowing motor switches off automatically when not pressing shirt.
- Productivity from 500 to 600 pc/8 hours working days

TECHNICAL FEATURES BP1808 SINGLE

Electric Connections		Mod 1808 Single
Standard voltage		
400V-3Ph-50Hz	kW	4
other voltages available on request		
Vacuum and blowing fan power	kW	2,2
Super heating device	kW	1
Steam and air connection		
Steam inlet	inch	1/2 "
Steam outlet	inch	1/2 "
Steam supply	Kpa	400 - 600
Steam supply	bar	6
Steam consumption	kg/h	40-45
Compressed Air inlet	inch	1/4 "
Compressed Air supply	Kpa	600-800
Compressed Air supply	bar	7
Shipping details		
Packing type		Pallet+carton box
Packing size	mm	2000 x 1600 x 2100H
Net weight	kg	650
Gross weight	kg	700

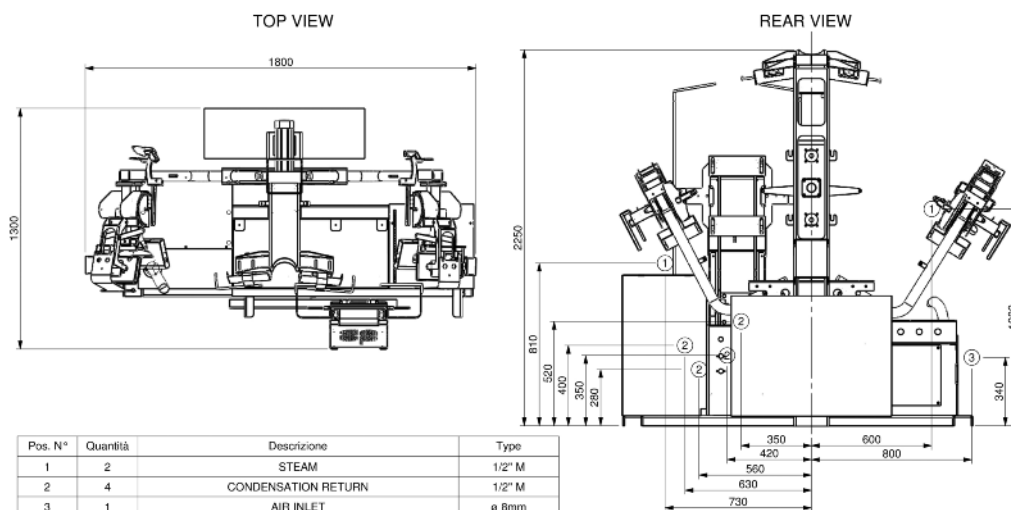

ROTONDI group Srl
 Via Fratelli Rosselli, 14/16
 20019 Settimo Milanese (Milano) - Italia
 Tel. (+39) 02.335.01.224 - Fax (+39) 02.335.01.329
 E-mail: rotondi@rotondigroup.it
www.rotondigroup.com

Agente: